



# Model: PIM-E Powerline Interface Module ELKM1 Data Bus

## Installation Guide and Owner's Manual

### FUNCTION

The PIM-E is a special Powerline Interface Module containing a built-in M1XSP Serial Port chip. This all-in-one device makes it easy to permanently connect the ELK M1 Control to a UPB network. Simply locate a convenient unused AC Power Outlet, connect a cable from the M1 data bus to the four (4) terminals on the PIM-E, and perform an M1 data bus enrollment. The long distance capability of the M1 data bus makes it possible to locate the PIM-E virtually anywhere, without a lot of complex or ugly cabling or connections. UPB utilizes the AC wiring circuit for transmission, without new or additional wiring, and without radio frequency signals. **Note: The PIM-E will not work with UPStart configuration software.**



### Connecting to M1 Control using a single homerun cable.

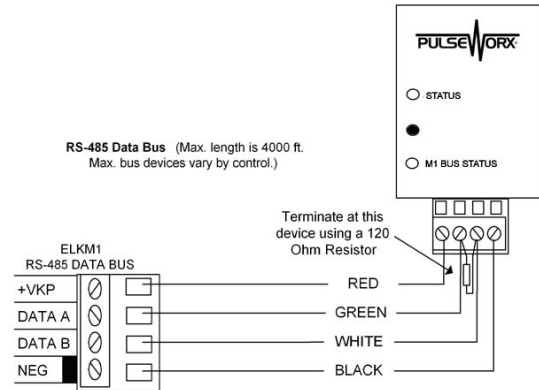

### M1 application using two (2) data bus homerun cables

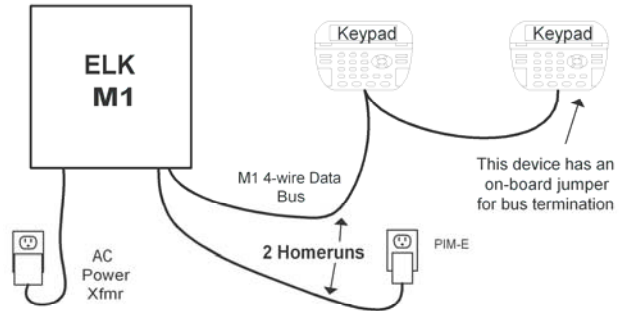

Ideally the M1 should have no more than 2 Data Bus home runs. The end of each homerun should terminate with a 120 Ohm resistor. Many M1 devices have a jumper for this purpose. See other wiring diagrams.

### IMPORTANT SAFETY INSTRUCTIONS

When using electrical products, basic safety precautions should always be followed, including the following:

1. READ AND FOLLOW ALL SAFETY INSTRUCTIONS.
2. Keep away from water. If the product is exposed to water or other liquid, turn off the circuit breaker and unplug the product immediately.
3. Never use products that have been dropped or damaged.
4. Do not use this product outdoors.
5. Do not use this product for other than its intended purpose.
6. To avoid any risk of fire, burns, personal injury or electric shock, install this product out of the reach of small children.
7. Do not cover product with any material when in use.
8. This product uses grounded plugs and sockets to reduce risk of electric shock. These plugs and sockets fit only one way. If they do not fit, consult an electrician.

### Connecting devices on an ELK-M1DBH Data Bus Hub

An ELK-M1DBH Data Bus Hub (Optional) Can be used to connect data bus devices using Cat5/6 cables. Devices appear to be in daisy chain because 1 wire pair returns the data bus back where it's used to feed next device OR gets terminated by special RJ45 Plug. Only 6 of the 8 total conductors are used.

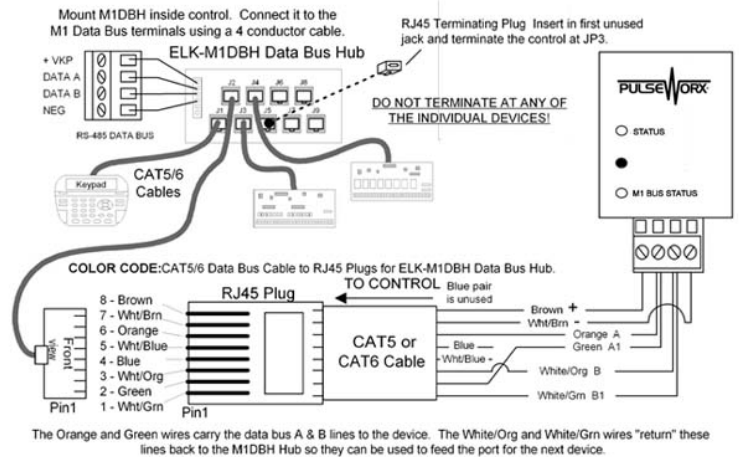

SAVE THESE INSTRUCTIONS.

### INSTALLATION

This device is designed for indoor use only. Follow these steps to connect the PIM-E module to the ELK M1 Control.

1. Connect a four-conductor cable from the M1 RS485 Data bus to the four (4) terminals on the bottom of the PIM-E. Observe polarity and color code from diagram.
2. Plug PIM-E into any grounded wall outlet. The Status LED should start blinking and then stay solid blue.



19201 Parthenia St. Suite J  
Northridge, CA 91324  
P: 818.701.9831 F: 818.701.1506  
pwxsales@pcslighting.com  
www.pcslighting.com



# Model: PIM-E

## Powerline Interface Module

### ELKM1 Data Bus

# Installation Guide and Owner's Manual

## CONFIGURATION

1. From M1 Keypad Programming (or ElkRP Software) perform a Data Bus Enrollment. Upon successful enrollment, the PIM-E should display as a "M1XSP" located at data bus Address #7. **This address is factory set and cannot be changed.** If another M1XSP is installed on the M1 and assigned Address #7 please change its address and re-enroll.
2. From ElkRP Software, select the "Globals" Menu and then tab "G29-G42 (Special)". On this tab locate and program the UPB Lighting Network Addr (1-255) to match the address chosen for the UPB network.
3. Program the format for each ElkM1 Lighting device as "Serial Expander".

### UPStart Configuration

PCS's free UPStart software V 5.1 Build 45 ,a Powerline Interface Module PIM-R (9-pin serial) or a PIM-U (USB serial), are used for computer setup and programming of a UPB network. These PIM's can be carried with the technician's PC and used on future jobs. The PIM-E can only be used with the ElkM1 and is not for PC setup or programming. The UPStart User's Guide (available on the PulseWorx web site: [www.PulseWorx.com](http://www.PulseWorx.com)) explains how to configure your system using the UPStart.

Follow the steps described below to configure PIM-E:

#### SETUP Mode

When configuring a UPB system, it will be necessary to place the PIM-E in SETUP mode. To do this, press the Program Button 5 times rapidly. The Status LED will continuously blink Blue when the device is in SETUP mode. To exit SETUP mode, press the Program Button once or wait five minutes for it to time out.

#### Step 1: Add the PIM-E to the UPB Network

Select the **Device→Add** menu item in the UPStart Setup Software. Once UPStart finds your PIM-E it will produce a screen allowing you to assign it a name and choose what room it is located in.

#### Step 2: Start PIM-E Configuration

Double-click the PIM-E icon to begin configuration. Select the **Advanced** tab to set the receive sensitivity.

The PIM-E has an adjustment for UPB receive sensitivity. The factory default for this setting is "High". If the PIM-E is used in severe powerline noise, you may find that it operates better in the "Low" receive sensitivity setting.

To adjust the receive sensitivity press the "Advanced" button on the UPB Interface Setup dialog. Select the desired receive sensitivity and press the "OK" button.

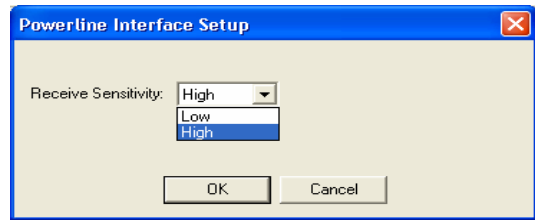

#### Step 3: Program the PIM-E

Once you have specified the desired configuration, press the Program Device button to program the information into the PIM-E.

#### Factory Default

In addition to Setup Mode the push-button on the front of the case can be used to restore the device to factory default settings. To set the factory defaults first press the pushbutton 5 times rapidly. The Status LED will blink blue. Next, press the pushbutton 10 times. The Status LED will blink red. Finally, press the pushbutton 2 times. The Status LED will stop blinking. The device is now restored to its factory default state.

Network ID:	255
Unit ID:	45
Network Password:	1234

## OPERATION

Once installed and configured your PIM-E will operate without further user intervention. All programmed data is protected by nonvolatile memory and can only be changed or deleted by reprogramming, regardless of power outage durations.

#### Status LED Indications

The PIM-E contains two bi-color (blue/red) Status LEDs that give a visual indication of what UPB information is currently on the powerline and communication with the M1 Bus.

#### UPB STATUS

Blue:	No UPB Signal
Magenta:	Received a UPB Message
Red:	Transmitted a UPB Message

#### M1BUS STATUS

Slow Blink :	Normal Communication with M1
Fast Flicker:	Command being sent or received to M1
No Blink/Off	Communication lost with M1

## LIMITED WARRANTY

Seller warrants this product, if used in accordance with all applicable instructions, to be free from original defects in materials and workmanship for a period of five years from the date of purchase. Refer to the warranty information on the PulseWorx website ([www.PulseWorx.com](http://www.PulseWorx.com)) for exact details.

These products may be covered under one or more of the following U.S. patents: 6,734,784; 6,784,790; 7,265,654; 7,688,183. U.S. and foreign patents may be pending. PCS, PulseWorx, UPB are registered trademarks and PulseWorxRF are trademarks of Powerline Control Systems, Inc. Made and printed in the U.S.A.

