



Split-Phase Repeater SPR Description

Version 1.2 10/24/07



19201 Parthenia Street,
Suite J
Northridge, CA 91234

P: 818.701.9831
F: 818.701.1506

sales@pcslighting.com



Table of Contents

1. Split-Phase Repeater Overview.....	1
1.1. Why Do I Need an SPR?.....	1
2. The SPR Solution	4
2.1. When Can I Use An SPR?	5
2.2. When Can't I Use An SPR?.....	5
3. SPR Installation Instructions	6
4. Using Your SPR	7
4.1. Diagnostic LED Indications	7
5. Adjusting Receive Sensitivity	8
6. UPStart And The SPR	10
7. About Multi-Packet Messaging.....	12

1. Split-Phase Repeater Overview

Powerline Control Systems, Inc. (PCS) is proud to add the UPB™ Split-Phase Repeater (SPR) to its PulseWorx™ line of home automation products. The SPR is a small electronic device (Figure 1) that is designed to enhance the communication reliability between devices that use the Universal Powerline Bus (UPB™) method of communication (such as PulseWorx™ devices). It is designed to be used in a typical residential 120/240VAC split-phase electrical environment. The SPR comes in both plug-in and wire-in models. The main purpose of the SPR is to take UPB™ messages transmitted on one phase (leg) of the electrical system and strongly repeat them onto both phases (legs).

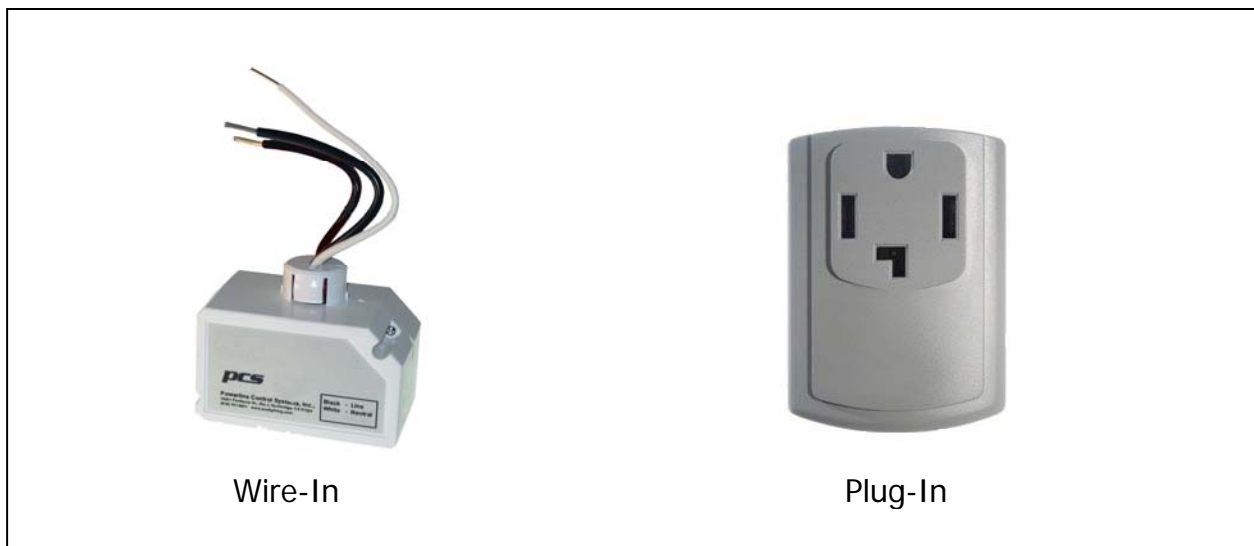

Figure 1: The Split-Phase Repeater (SPR)

1.1. Why Do I Need an SPR?

In most cases you don't. The UPB™ signal is strong enough to travel from a transmitting device throughout the entire electrical system of the home. There are usually no UPB™ communication problems with the typical home. We use the terms "usually" and "typical" to insinuate that occasionally you will run into a UPB™ installation with problems that need to be solved. The SPR is designed to be a powerline problem solver for homes with extreme noise or other issues with their powerline.

The Line Attenuation Problem

Other electrical appliances that use (are plugged in to) the powerline attenuate (or suck down) the strength of the UPB™ signals (see Figure 2). Also, long runs of electrical wire (or multiple distribution panels) between the transmitter and receiver serve to further attenuate the UPB™ signals. This attenuation affect is typically insignificant enough to not affect the UPB™ communication throughout the home. UPB™ uses signals that are very strong (typically 50V peak). Most homes either do not have enough electrical appliances or do not have the wrong type of electrical appliances to attenuate the UPB™ signal strength enough to cause it to fail.

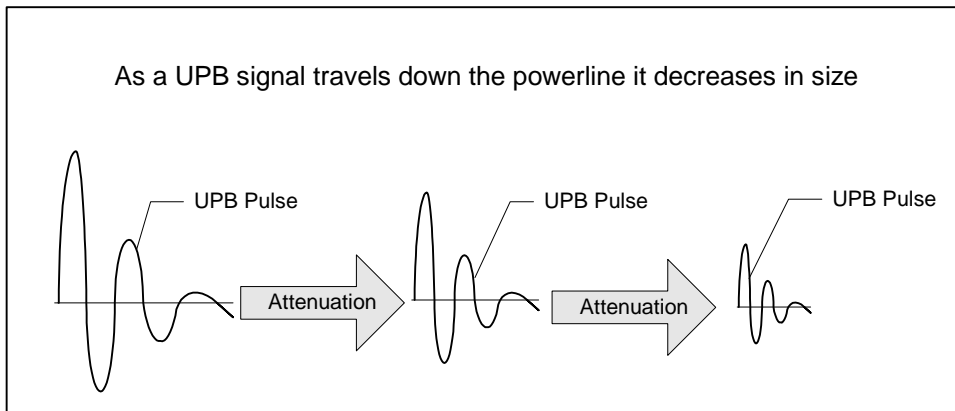

Figure 2: Line Attenuation

The Cross-Phase Attenuation Problem

Most homes in the United States are wired to an electrical transformer that supplies two phases (or legs) of 120VAC electrical power to the home’s main circuit breaker panel. About half of the electrical devices/outlets are supplied by one leg of the transformer while the other half is supplied by the other leg of the transformer. When UPB™ signals are transmitted by a device on one phase to a receiving device on the other phase they must travel all of the way through the electrical transformer to get to the other leg (see Figure 3). The electrical transformer attenuates (or weakens) the strength of the UPB™ signals. Again, the UPB™ signal is strong enough, in most cases, to get through the transformer without any communication problems.

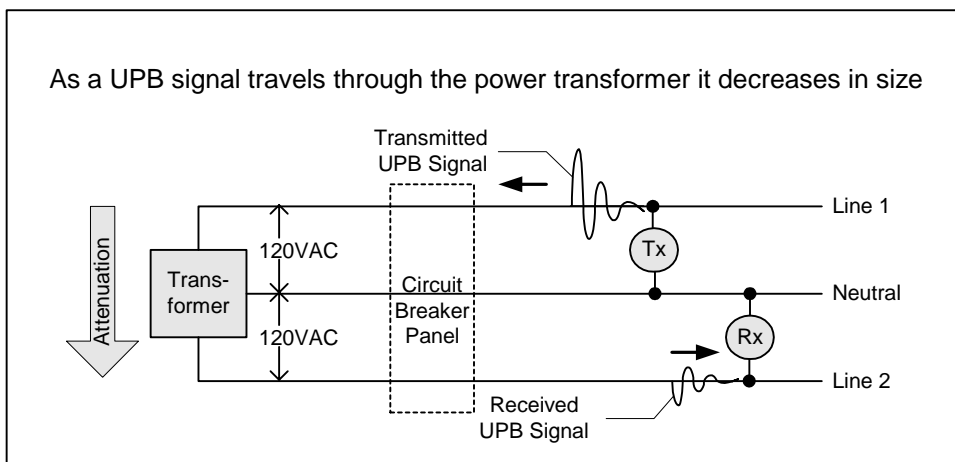

Figure 3: Cross-Phase Attenuation

PCS currently has a line of devices called Passive Phase Couplers (PPC) that do a very good job at solving the Cross-Phase problem. The PPC wires to the two powerline legs and serves as a “bridge” for the UPB™ signal to take to get from one leg (phase) to the other. The UPB™ signals going through the PPC still get attenuated (weakened) but not nearly as much as when they go through the electrical transformer.

The Powerline Noise Problem

Some electrical products (such as some microwave ovens, plasma televisions, transformers, and florescent lighting ballasts) generate electrical noise onto the powerline. This noise, if strong enough and generated in the wrong area of the power waveform, can make it harder for the UPB™ receiver to distinguish the real UPB™ signal from the noise signal (see Figure 4). Again, the UPB™ signal is typically strong enough, in most cases, to be easily distinguished from the typical powerline noise put out by these other products.

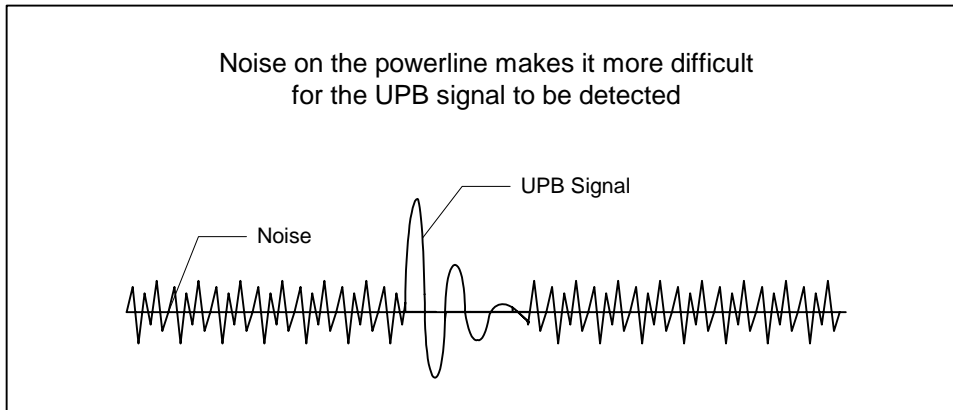

Figure 4: Powerline Noise

The Combination Problem

The strength of the UPB™ communication method is that, for the most part, it overcomes the powerline problems described above. No other powerline technology to date has been so reliable. However, when all three powerline problems exist together at a severe enough level the UPB™ communication method can experience some failures (see Figure 5). For instance, a home with a combination of high powerline noise and high signal attenuation may experience some communication problems.

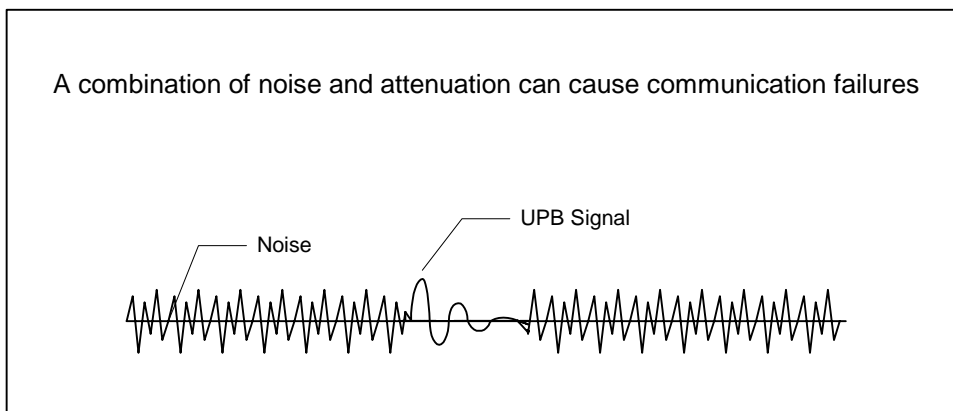

Figure 5: Combination of Noise & Attenuation

2. The SPR Solution

The Split-Phase Repeater is the next level in solving UPB™ powerline communication problems. Rather than just allowing UPB™ signals to pass through it (and suffering some signal attenuation) – as a Passive Phase Coupler does, the SPR receives the complete UPB™ message and actively re-transmits it onto both legs of the powerline (see Figure 6). This results in very strong UPB™ signals that exist on both legs of the powerline.

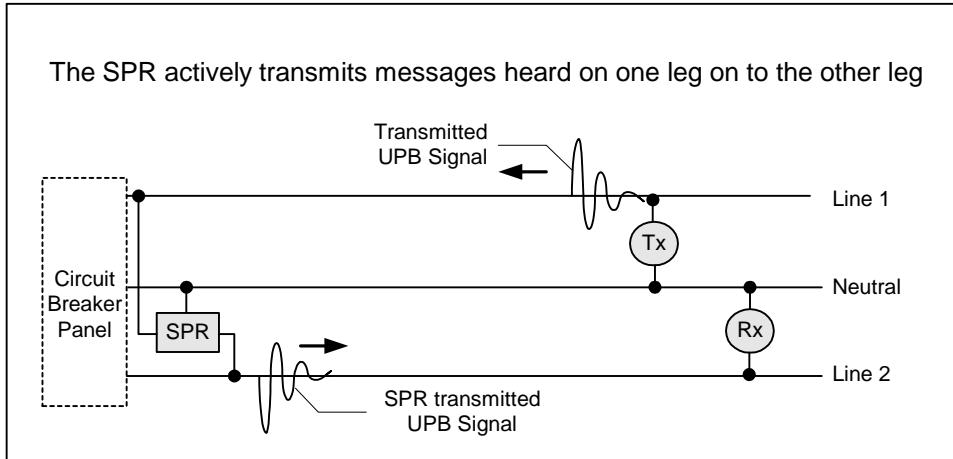

Figure 6: The SPR Actively Transmits on Both Legs

In many cases, it is a good idea to install an SPR in a problem-free home to ensure that possible future attenuation and noise problems don't cause any degradation in the UPB™ communication reliability.

2.1. When Can I Use An SPR?

Any home that uses 60Hz split phase 120/240VAC electrical power can take advantage of an SPR to improve the UPB™ communication reliability. The Split-Phase Repeater is a Generation II UPB™ device. It uses a mechanism that is built into the Generation II UPB™ protocol, called multi-packet messaging, to operate (refer to section 7. for an explanation of the multi-packet messaging mechanism). Generation II UPB™ devices, controllers, and setup/configuration tools that fully support multi-packet messaging can take full advantage of the SPR. The Split-Phase Repeater is designed to be plug-and-play – just install it and forget about it. There are no special setup/configuration steps necessary to begin using the SPR¹.

2.2. When Can't I Use An SPR?

The SPR is not recommended for use with Generation I UPB devices:

Unfortunately, old Generation I UPB™ devices did not fully support the multi-packet messaging mechanism. These “older” devices only allow multi-packet messaging to be used for one-way communication. Even with this limitation, Generation I UPB™ devices may still make use of the SPR for performing one-way command transfers. Many, if not most of, existing Generation I UPB™ systems do not rely on two-way communication for normal operation. These systems only require commands to be sent from one (or more) transmitting device(s) to one (or more) receiving devices. They do not expect the receiving devices to transmit anything back. In this situation, the SPR will undoubtedly improve the one-way communication reliability.

The SPR is not recommended for use with Generation I UPB™ Controllers:

Most home automation controllers support Generation I UPB™ devices. In order to make full use of the Split-Phase Repeater these controllers will need to be upgraded to Generation II UPB™ support. In most cases this is a simple upgrade to support the multi-packet messaging mechanism. We recommend that you consult your controller manufacturer’s documentation to determine if it supports the Generation II UPB™ multi-packet messaging mechanism.

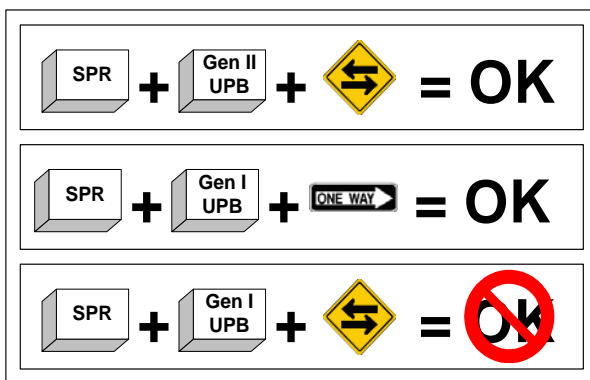

Figure 7: When Can and Can't You Use an SPR

¹ Although the SPR will work right out of the box, it should be added to your UPStart configuration file to allow it to filter out neighboring networks and to allow for testing and troubleshooting.

3. SPR Installation Instructions

The Split-Phase Repeater comes in two different packaging styles: wire-in and plug-in (refer to Figure 1).

Wire-In SPR Installation

The SPR provides the best results if installed in or near the main circuit breaker panel. The wire-in SPR comes with a plastic nipple that is designed to fit in a standard ½" knock-out for good mechanical support. Follow the installation instructions that are included with the product to properly install/wire it.

Wiring Instructions

The SPR works best if wired to the main circuit breaker panel. The wire-in SPR provides two black wires and one white wire. Connect one black wire to one of the two 120VAC 60Hz phases of the powerline. Connect the other black wire to the other of the two 120VAC 60Hz phases of the powerline. Connect the white wire to the neutral bus.

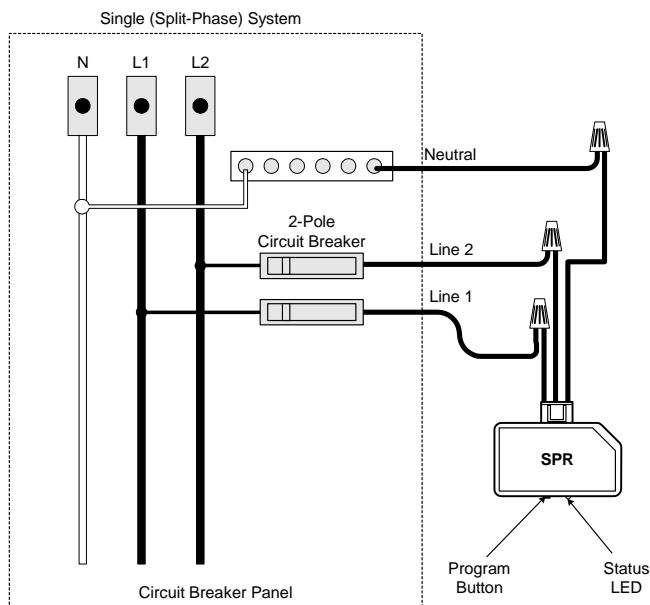

Figure 8: SPR Wiring Diagram

Note: if your SPR is wired incorrectly its Status LED will not stay lit up.

Plug-In SPR Installation

The plug-in SPR plugs in to a standard 240VAC electric clothes dryer (or electric stove) outlet. Both 3-prong and 4-prong configurations are available. It has a pass-through electrical outlet so that your clothes dryer can still obtain power while the SPR is plugged into the outlet.

4. Using Your SPR

The Split-Phase Repeater is designed to be “Plug-and-Play” – just install it and forget about it. It will automatically repeat all multi-packet messaging transmissions that it hears in order to enhance the UPB™ communication reliability of your network. All PulseWorx™ devices (and most other UPB™ devices) are pre-configured at the factory to use multi-packet messaging.

Using Your SPR With UPStart

By default, UPStart does not use multi-packet messaging when it talks to your devices. This is done to enable UPStart to perform two-way communication with the older Generation I UPB™ devices. UPStart needs to be told that an SPR exists in the network so that it will switch to using multi-packet messaging for its two-way communication with Generation II UPB™ devices. The way you tell UPStart to do this is to add the SPR to your network file the same way you add all of your other UPB™ devices. Once your SPR is added to your network file, UPStart will be able to:

- 1) Make use of it to enhance the two-way powerline communication reliability
- 2) Stop it from repeating a neighboring network
- 3) Allow you to perform communication tests with it
- 4) Allow you to make adjustments to its configuration using UPStart

Refer to Section 6. to learn more about the SPR and UPStart.

Using Your SPR With Home Automation Controllers

By default, Home Automation Controllers do not use multi-packet messaging when they talk to your UPB™ devices. This is done to enable the controller to perform two-way communication with the older Generation I UPB™ devices. In order to make use of the SPR your home automation controller needs to be told to switch to using multi-packet messaging for its two-way communication with Generation II UPB™ devices. Consult the documentation provided with your home automation controller to learn how to switch to multi-packet messaging.

4.1. Diagnostic LED Indications

The SPR has a single bi-color status LED that provides you with useful information for diagnosing problems on the powerline as described in Table 1 below.

Status LED Behavior	What It Indicates
Flashes Off	The SPR received a UPB packet that is non-repeatable.
Flashes Magenta	The SPR received a UPB packet that is repeatable.
Flashes Red	The SPR is transmitting onto the powerline.

Table 1: Status LED Diagnostic Behavior

5. Adjusting Receive Sensitivity

The SPR is capable of being set to one of four possible Receive Sensitivities (see Note 1 below) to allow it to be customized for optimal operation in the particular environment it is installed in. Your SPR comes from the factory set to its HIGHEST receive sensitivity. For most residential environments this is a good setting and no adjustment is necessary.

Why Do I Need To Adjust This?

In most cases the SPR will be unaffected by powerline noise. If your house has particularly severe powerline noise you may need to decrease the SPR's Receive Sensitivity to get it to communicate properly. Lowering the receive sensitivity will decrease the strength of the noise that gets into your SPR (see Figure 9 below). However, lowering the receive sensitivity will also decrease the strength of the signal that gets into your SPR. Therefore, you may have to "adjust" the settings to find the receive sensitivity that reduces the noise enough to allow proper powerline communication.

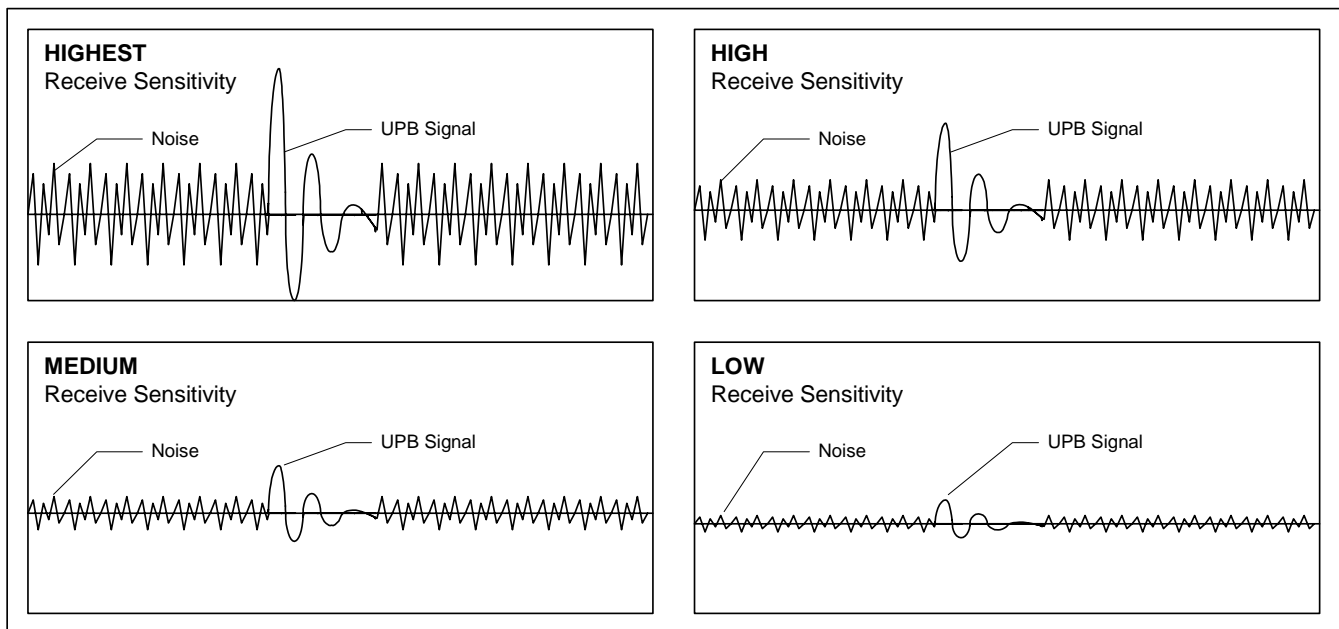

Figure 9: Receive Sensitivity Affects Noise and Signal

How Do I Adjust The Receive Sensitivity?

There are two ways to adjust the receive sensitivity of your SPR. One way is to use the UPStart Setup software as explained later on in section 6. . The other way to adjust the receive sensitivity is to use the push-button and status LED on the front of the SPR as described in Table 2 below.

Step	Operation to Perform	Expected Result
1	Press and hold the Push-button several seconds until the Status LED starts to blink.	The Status LED will begin to blink after about 3 seconds of holding the Push-button.
2	Release the Push-button.	The Status LED will blink red for 1, 2, 3, or 4 blinks to indicate the current receive sensitivity (see note 1).
3	Tap the pushbutton 1, 2, 3, or 4 times to select the desired receive sensitivity (see note 1).	The Status LED will blink red for 1, 2, 3, or 4 blinks to indicate the new receive sensitivity (see note 1).
4	Press and hold the pushbutton several seconds until the Status LED stops blinking.	The Status LED will stop blinking after about 3 seconds of holding the pushbutton.
5	Release the pushbutton.	The Status LED should no longer be blinking.

Table 2: Procedure To Adjust Receive Sensitivity

Note 1: Receive Sensitivity 1 = Low, 2 = Medium, 3 = High, 4 = Highest.

6. UPStart And The SPR

The UPStart Setup Software (available for free at www.PulseWorx.com) is a powerful software tool for setting up, configuring, and troubleshooting your UPB™ network. It operates on a PC or laptop computer and uses a Powerline Interface Module (PIM) to interface with the powerline.

Adding The SPR To UPStart

As explained in section 4. , the SPR needs to be added to your network configuration file in order for UPStart to identify it and use it. The SPR is added to UPStart like most other UPB devices. Just select Device→Add and put the SPR into Setup Mode (by tapping its Push-button 5 times). UPStart will find your SPR and allow you to name it.

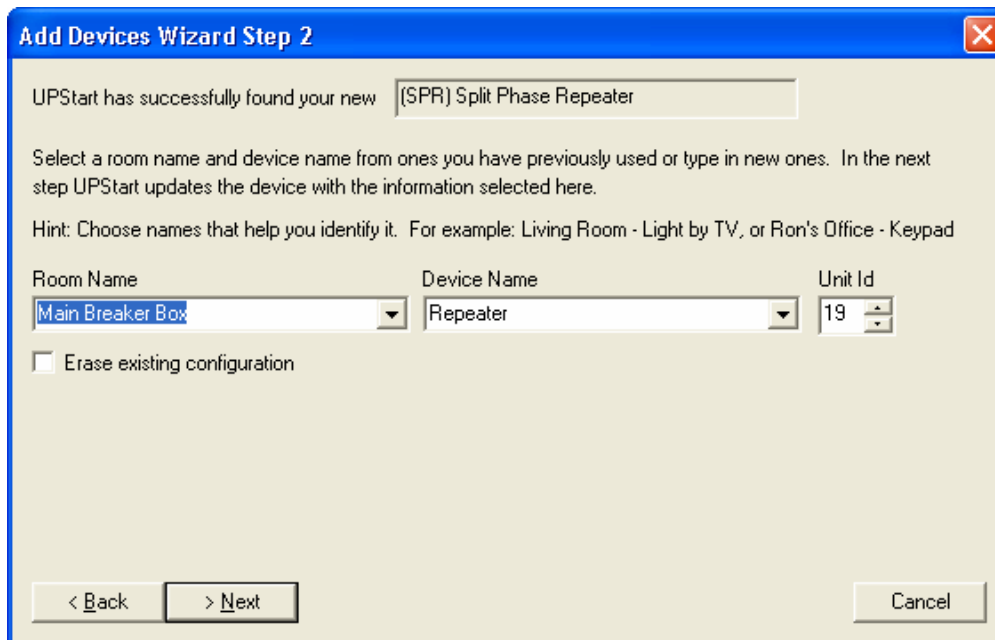

UPStart will then add your SPR to the configuration file and assign it your designated name, Network ID, and Network Password. UPStart will display an icon for the SPR and it will allow you to edit and test it like any other UPB device.



Unit 014
Main Breaker Box
Repeater

Adjusting The SPR Receive Sensitivity Using UPStart

The Edit Device dialog for the SPR has a control (on its “Advanced” tab) for adjusting its Receive Sensitivity to any of four different settings.

Adjusting The UPStart-To-Device Transmission Count

The Edit Device dialog for the SPR has a control (on its “Advanced” tab) for adjusting how many multi-packets (2, 3, or 4) UPStart should use to communicate with other devices while using the SPR. This value defaults to “2 times”. By setting it to 3 or 4 times UPStart will obtain more reliable results but operations will take longer to complete. This control is recommended to be left at “2 times” unless UPStart communication reliability is a problem. If this control is set to “1 time” then UPStart will not use the SPR in its operations.

Adjusting The UPStart-To-SPR Transmission Count

The Edit Device dialog for the SPR has a control (on its “Advanced” tab) for adjusting how many multi-packets (1, 2, 3, or 4) UPStart should use to communicate with the SPR. This value defaults to “1 time”. By setting it to 2, 3, or 4 times UPStart will obtain more reliable results but operations will take longer to complete. This control is recommended to be left at “1 time” unless UPStart communication reliability is a problem.

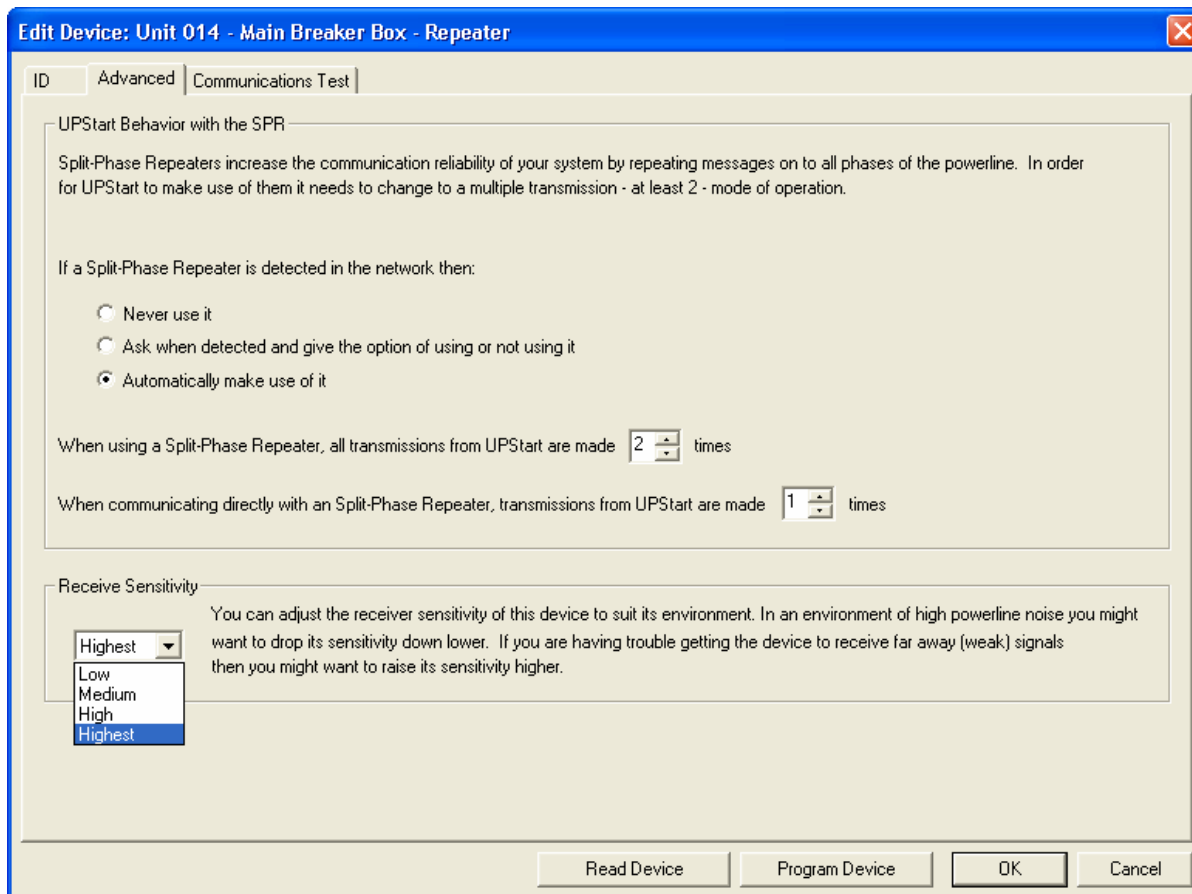

7. About Multi-Packet Messaging

The Split-Phase Repeater operates using a mechanism called multi-packet messaging. Multi-packets are special communication packets built into the UPB™ protocol that transfer the same information (command or report) 2, 3, or 4 times in a row. Figure 10 shows a 4-time multi-packet sent from the requesting device. Each individual part of the multi-packet that contains the information is called a Section. Special fields (CNT and SEQ) within each packet section specify whether it is the "1 of 4", "2 of 4", "3 of 4", or "4 of 4" section.

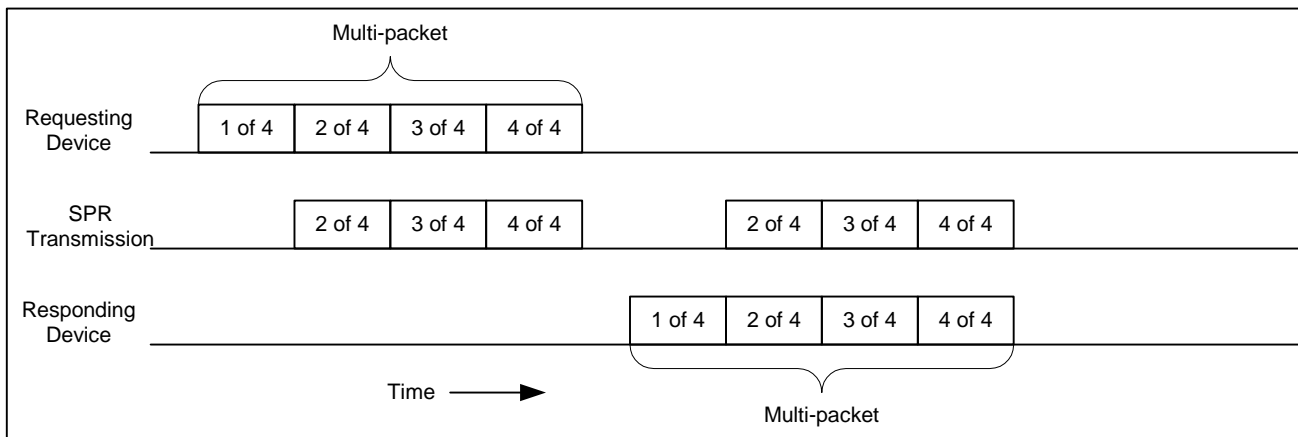

Figure 10: Multi-Packets Get Repeated By The SPR

Because the information is transmitted multiple times there is an inherent increase in the chances that the transfer will be successful. If some sort of a glitch on the powerline ruins one part of the multi-packet chances are good that the other part(s) will be successful.

All PulseWorx™ devices (and most other UPB™ devices) are pre-configured at the factory to use 2-time multi-packet messaging. Even with multi-packet messaging, however, communication problems can still exist on some powerline environments (refer to section 1.1.).

The SPR is designed to transmit the trailing sections (2 of 4, 3 of 4, and 4 of 4) of a multi-packet overlapped on top of the originating transmitter's sections. This results in a very strong UPB™ signal on both legs of the powerline. This increased signal strength is usually enough to get the information successfully transferred in even the toughest powerline environment.



19201 Parthenia Street, Suite J
Northridge, CA 91234

P: 818.701.9831
F: 818.701.1506

sales@pcslighting.com
www.pcslighting.com