



ELV Wall Switch Dimmer and Remote Wall Switch

INSTALLATION AND OWNER'S GUIDE

For Models:

WS1E-3, WS1E-5 (Wall Switch Dimmers)
RWS (Remote Wall Switch)



READ THESE INSTRUCTIONS BEFORE INSTALLING DEVICE

Note: The WS1E is perfect for controlling electronic low voltage AC lighting ballasts and transformers. These types of transformers usually have a note such as:

"Fully dimmable using a dimmer designed for an electronic transformer. An electronic transformer can sometimes work with a standard incandescent dimmer. However, to ensure that your lighting system works effectively with the greatest dimming range we recommend that you use a dimmer that was specifically designed to control an electronic low voltage transformer. Additionally, using this type of dimmer will diminish the possibility of an audible hum when the dimmer is used – especially at low light levels."

This Wall Switch Dimmer is intended for installation in accordance with the National Electrical Code and local regulations. It is recommended that a qualified electrician perform this installation. Retain these instructions for reference or download the manual from www.PulseWorx.com.

To reduce the risk of overheating and possible damage to other equipment, do not use switch, when set to dimming-capable, to control a receptacle, a motor-operated appliance, a fluorescent lighting fixture or a transformer-supplied appliance. This product is for indoor use only. Connect only copper or copper clad wire to this device.

Important Notes Prior To Installation

1. All PCS PulseWorx™ Wall Switch Dimmers require a neutral (white) connection wire.

About Your WS1E Wall Switch Dimmer

The WS1E Wall Switch Dimmer (Figure 1) is a high quality light-switch/ dimmer that not only allows for local rocker switch control of *electronic low voltage* AC lighting ballasts or transformers but also incorporates PCS's innovative UPB™ two-way powerline communication technology that gives it the ability to be remotely controlled by other UPB™ compatible controllers. The WS1E is highly configurable to allow for behaviors customized to each individual's desires. The WS1E is capable of storing up to 16 preset light levels and fade rates to create powerful lighting scenes. The WS1E is also capable of transmitting UPB™ messages (including a current light level report) when rocker switch events occur. The WS1E is capable of being set to a non-dimming mode in order to control such loads as fluorescent lights.

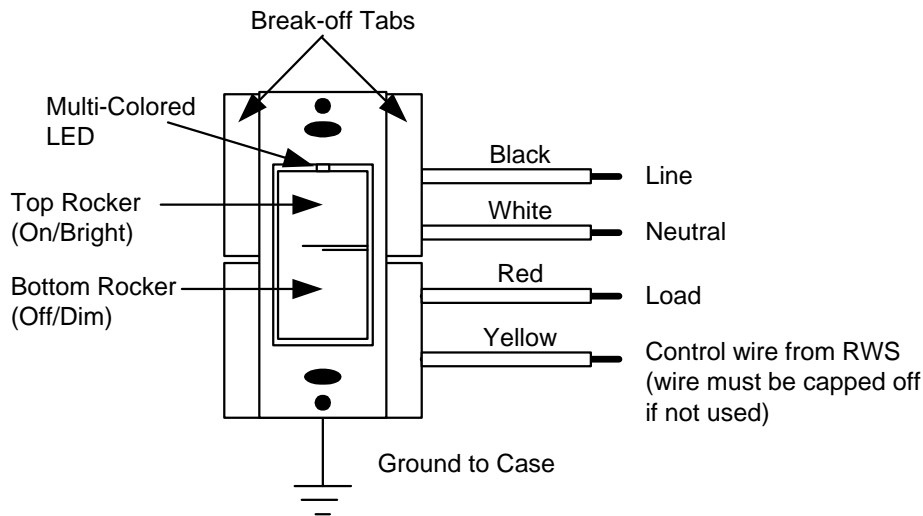

Figure 1: WS1E Wall Switch Dimmer

About Your RWS Remote Wall Switch

The RWS Remote Wall Switch (Figure 2) is a low cost (optional) companion device to the WS1E Wall Switch Dimmer. The RWS has a Decora-style rocker switch that controls the WS1E in the same exact way that its local rocker switch does.

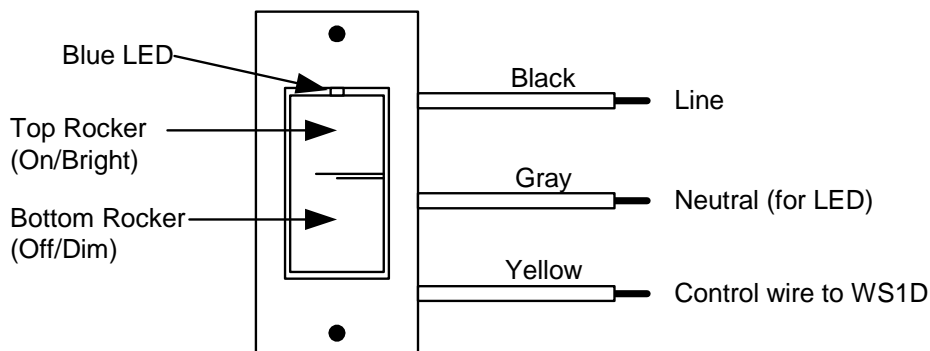

Figure 2: RWS Remote Wall Switch

Installation Instructions

The Wall Switch Dimmer is wired directly to the lighting circuit and can (optionally) be controlled by one or more RWS Remote Wall Switches producing three, four, or five-way circuits. Multi-way circuits make it possible for a group of switches to control the same set of lights. This section will illustrate how to hook-up the connections.

Notes:

- 1. Refer to Figures 1 and 2 to determine the wire colors of the hook-up.
- 2. All PCS Wall Switch Dimmers require a neutral (white) connection.
- 3. Remote Wall Switches require that the Line (black) wire be accessible. This wire may be connected to either phase of the 120/240V supply.
- 4. The gray wire on the Remote Wall Switch can be connected to either earth ground or neutral. The gray wire serves only to light the LED in the remote. This LED does not indicate anything except that power is applied and to serve as a night-light.

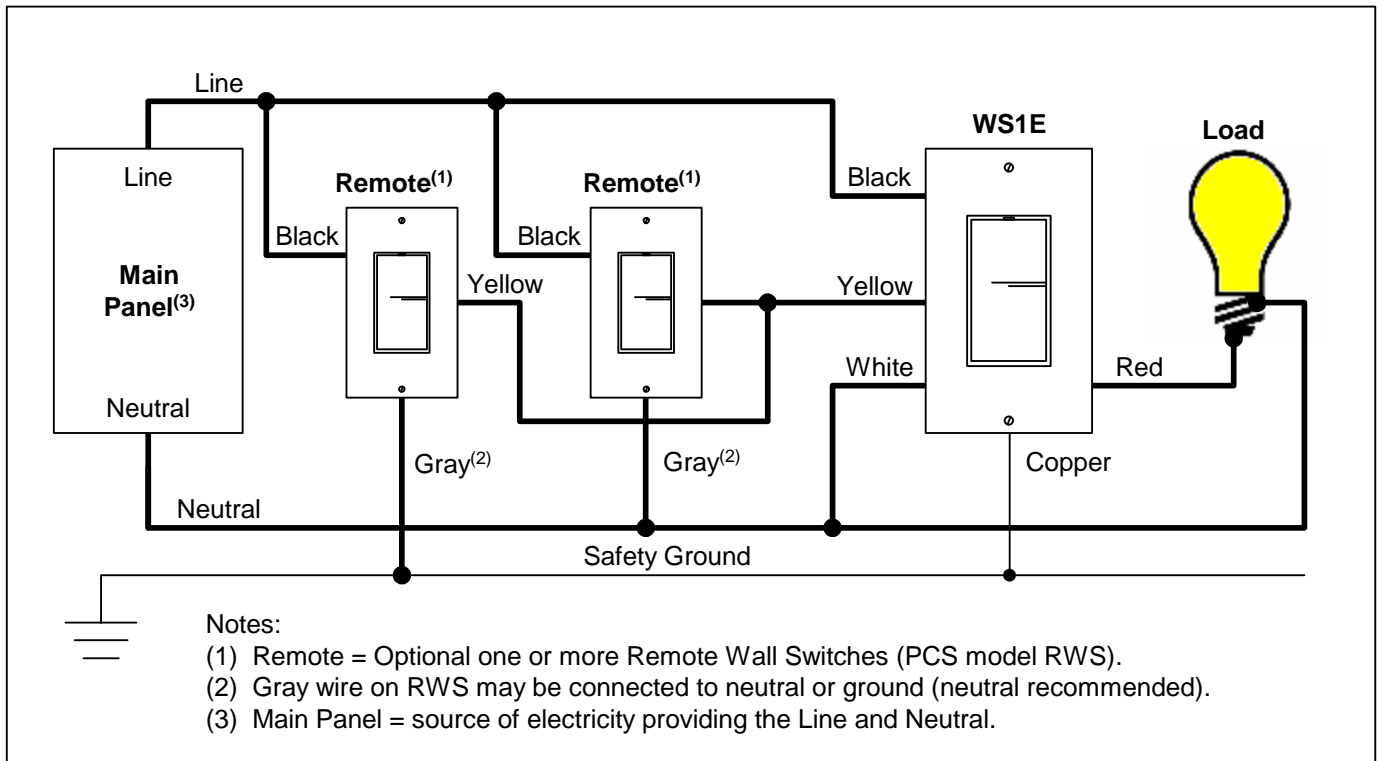

Figure 3: Wiring Diagram

Air-Gap Switch

The WS1E rocker switch has an air-gap switch that will remove all power from the load for safe installation and bulb replacement. To activate the air-gap switch firmly press the rocker bottom until you hear a loud “click” or you see the SYSTEM “OFF” label on the top rocker.

Installation Procedure

1. Remove the faceplate from the existing wall switch.
2. Unscrew and pull the existing wall switch out of the wall box.
3. Disconnect the wires from the existing wall switch. Identify the “Line”, “Neutral”, “Load” and “Traveler” wires.
4. Install the WS1E Wall Switch connecting wires per wiring configuration shown in Figure 3.
Note: Be sure that the WS1E Wall Switch is in the SYSTEM “OFF” position by firmly pressing the Rocker Bottom until you click the air-gap switch to the open position or you see the SYSTEM “OFF” label on top of the Rocker.
5. Optionally install any RWS Remote Wall Switch per wiring configuration shown in Figure 3.
6. After all connections have been made, be certain that all wire connectors are firmly attached and there is no exposed copper.
7. Gently place the wires and Wall Switch into the wall box, with light emitting diode (LED) at the top of device, and screw in place.
8. Before installing the faceplate, restore power to the circuit, and firmly press the top of the Wall Switch Dimmer until it snaps out of the SYSTEM “OFF” position.
9. After testing the Wall Switch Dimmer for proper local operation (per Table 2), install the faceplate cover(s) to the outside of the Wall Switch Dimmer(s).

De-rating Information

For a proper fit in a multiple gang installation, it may be necessary to remove one or both sides (break-off tabs) from the mounting plate (see Figure 1). When tabs are removed, the overall rating of the device must be reduced in accordance with the following chart:

Model	Device Maximum Load	No Fins Removed Deep Box	No Fins Removed Normal Depth Box	One Fin Removed Next to One Dimmer	Both Fins Removed Next to Two Dimmers
WS1E-3	300VA	300VA	300VA	240VA	180VA
WS1E-5	500VA	500VA	500VA	400VA	300VA

Table 1: Wall Switch De-rating Information

Using Your WS1E Wall Switch Dimmer

The WS1E Wall Switch Dimmer is packed full of different options and configurations that can be programmed into it using a UPB Setup Tool. This section will describe the operation of the Wall Switch Dimmer in its factory default configuration. Please refer to the section entitled “Configuring the WS1E Wall Switch Dimmer” for a description of the many other configuration options available.

Local Rocker Switch Operation

The WS1E Wall Switch Dimmer has a Decora-style rocker switch that can be used to control the lighting load. The factory default operation is described below in Table 2.

Rocker Event	Top Rocker	Bottom Rocker
Single-Tap	Brightens the light to 100% (on) at a 1.6-second fade rate.	Fades the light to 0% (off) at a 1.6-second fade rate.
Double-Tap	Snaps the light to 100% (on).	Snaps the light to 0% (off).
Hold	Starts fading (brightening) the light towards 100% at a 1.6-second fade rate.	Starts fading (dimming) the light towards 0% at a 1.6-second fade rate.
Release	Stops brightening the light.	Stops dimming the light.

Table 2: Rocker Switch Operation

Status LED Indicator

The WS1E Wall Switch Dimmer comes equipped with a multi-color status LED indicator that is normally lit to blue. This LED indicator will blink different colors to indicate UPB™ communication status and configuration status as outlined in Table 3 below. Note: By using UPStart Setup Software, the Status LED can also be configured to stay one solid color or to change colors based on the state of the load.

UPB™ Status	LED Color
No UPB™ message on the power line	Blue
Receives a UPB™ message for the switch	Magenta
Receives a UPB™ message for another device	Black
Switch is transmitting a UPB™ message	Red

Table 3: Status LED Operation

Using Your RWS Remote Wall Switch

The WS1E Wall Switch can (optionally) be connected to one or more RWS Remote Wall Switches producing three, four, or five-way lighting circuits. Each Remote Wall Switch has a Decora-style rocker switch that can be used to control the lighting load of the WS1E in the same way as previously described in Table 2.

Configuring the WS1E Wall Switch Dimmer

Once your WS1E is installed it can be configured either manually or with the UPStart Setup Software. Table 4 describes the many configuration options available that can be set. Manual configuration can be used to add your WS1E device into a UPB network, link it to controller buttons and change preset light levels. Refer to the Keypad Controller's Manual Configuration Guide available on the PulseWorx website (www.PulseWorx.com) for more details.

UPStart

Although the factory default operation of the WS1E is useful in many situations, it is highly recommended that your device be configured with the UPStart Setup Software so that you can take advantage of its many configurable features.

PCS has developed a Powerline Interface Module (PIM) and free software (UPStart) to help you configure all of your PulseWorx Lighting System devices. User's Guides are available on the PulseWorx web site: www.PulseWorx.com to explain how to configure your system.

Changing Preset Light Levels

The WS1E Wall Switch Dimmer is specially designed to work in a PulseWorx™ Lighting System consisting of PCS 6 and 8 button keypad controllers (PCS models KPCW-6, KPCW-8). Pushbuttons on these controllers can be configured to activate the Preset Light Levels and Fade Rates stored in the WS1E. Once configured, the homeowner can easily adjust the Preset Light Level that gets activated by a particular pushbutton by following this simple procedure.

Step	Operation
1	Press the pushbutton on the 6 or 8 button controller to activate the currently stored Preset Light Level.
2	Use the local rocker switch on the WS1E to adjust to the desired Preset Light Level.
3	Press the pushbutton on the 6 or 8 button controller five times quickly.
4	The WS1E will flash its lighting load one time to indicate that it stored the new Preset Light Level.

Putting the WS1E into Setup Mode

The WS1E Wall Switch Dimmer can be put into the Setup Mode (for UPB Setup Tool support) by the following steps:

Step	Operation
1	Tap the WS1E's local (or remote) rocker switch 5 times quickly.
2	The WS1E will flash its lighting load one time and blink its LED blue to indicate that it is in Setup Mode. Note: the device will automatically exit Setup Mode after 5 minutes.

Configuration Options

Option	Factory Default	Possibilities
Dimming	Enabled	Enabled or Disabled (on/off only)
Default Fade Rate	1.6 seconds	16 different fade rates from 0 (Snap) to 1 hour.
Top Rocker Single-Tap Action	Fade to 100% at the Default Fade Rate.	Any Level (0% - 100% including Last On Level) at any of 16 Fade Rates.
Bottom Rocker Single-Tap Action	Fade to 0% at the Default Fade Rate.	Any Level (0% - 100% including Last On Level) at any of 16 Fade Rates.
Top Rocker Double-Tap Action	Snap to 100%.	Any Level (0% - 100% including Last On Level) at any of 16 Fade Rates.
Bottom Rocker Double-Tap Action	Snap to 0%.	Any Level (0% - 100% including Last On Level) at any of 16 Fade Rates.
Top Rocker Max-Out	Disabled	Enabled or Disabled
Preset Light Levels and Fade Rates (Scenes)	1 - Link 1 - 100% 2 - Link 2 - 0% 3 - Link 3 - 80% 4 - Link 4 - 60% 5 - Link 5 - 40% 6 - Link 6 - 20% 7 - Link 8 - Blink .5 Sec	Link as many as 16 different Preset Light Levels and Fade Rates to components on UPB™ compatible controllers. An option is available to activate a light blinking mode.
Timed Auto-Off	Disabled	Disabled or Auto Shut-Off in 1 – 240 minutes
Timed Auto-off Transmit	Unused	Configure any of 15 different UPB Messages to be transmitted upon Auto-Off.
Top Rocker Switch UPB Transmissions	Disabled	Configure any of 15 different UPB Messages to be transmitted upon any Rocker Switch Event.
Bottom Rocker Switch UPB Transmissions	Disabled	Configure any of 15 different UPB Messages to be transmitted upon any Rocker Switch Event.
UPB Transmission Attempts	2	1, 2, 3, or 4 transmissions per event.
Report Light Level	Disabled	Enabled (send Status Report) or Disabled
UPB Receive Sensitivity	HIGH	HIGH or LOW
LED Color Control	Diagnostic LED (See Table 3)	Any of 16 different LED modes consisting of the colors blue, red, magenta, and black.

Table 4: WS1E Configuration Options

Setting Factory Defaults

The WS1E Wall Switch Dimmer can be set back to the factory defaults listed in Table 4 by the following steps:

Step	Operation
1	Identify the WS1E that you want to set factory defaults by tapping its rocker switch 5 times quickly.
2	The WS1E will flash its lighting load one time and blink its LED blue to indicate that it is ready to be set to factory defaults.
3	Set the factory defaults by tapping its rocker switch 10 times quickly.
4	The WS1E will flash its lighting load one time and blink its LED red to indicate that it has been set to factory defaults.
5	Tap the rocker 2 more times to stop the blinking.

SPECIFICATIONS

Model Number	WS1E-3	WS1E-5
Electronic Low Voltage Dimming	Yes	Yes
Inductive Loads Dimming	No	No
Fluorescent Loads Non-dimming	Yes (configurable)	Yes (configurable)
Power Maximum Dimming	300W / 300VA	500W / 500VA
Current Maximum Non-dimming	2.5A	4.1A
Connections	14 GA	12 GA
LED Indicator	Yes	Yes
Dimensions	4.68 X 2.75 X 1.25 in	4.68 X 4.5 X 1.25 in
Weight	0.3 lb.	0.3 lb.
Mounting	Standard J box	Standard J box
Input Power	120 ± 12 VAC	120 ± 12 VAC
Input Frequency	60 ± .3 Hz	60 ± .3 Hz
Operating Temp	-40 °F to 104 °F	-40 °F to 104 °F

Limited Warranty

Seller warrants this product, if used in accordance with all applicable instructions, to be free from original defects in materials and workmanship for a period of five years from the date of purchase. Refer to the warranty information on the PulseWorx website (www.PulseWorx.com) for exact details.